

TPA | AIR DRIVEN TORQUE WRENCH PUMPS - PREMIUM LINE



Working pressure 10000 psi

High flow 3-stage pump unit

Compact and lightweight

- ▶ Low noise operation (<90 db)
- ▶ Supplied fitted with one set of quick connect couplers
- ▶ Exhaust air radiator cooling system fitted as standard
- ▶ Adjustable torque setting pressure relief valve with locking nut
- ▶ Analog or digital gauge options
- ▶ Remote hand pendant controller with 16.5 feet cable for easy operation
- ▶ Multi-outlet 4-way split block for simultaneous operation of up to 4 torque wrenches
- ▶ Factory fitted roll bar protection and carrying frame

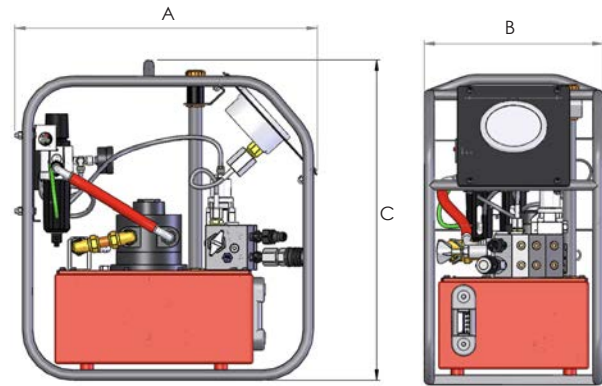

Model number	Power supply	Pressure gauge	Gauge reading	Flow rate (gallons/min)			Oil capacity (gallons)	Max. oil temp (°C)	Weight incl. oil (lbs)	Dimensions (in)		
				1 st stage (0-943 psi)	2 nd stage (943-4713 psi)	3 rd stage (4713-10000 psi)				A	B	C
TPA07A	1000 psi air	analog	psi/bar	427.17	97.64	48.82	1.85	80°	66.1	18.68	11.27	19.74
TPA07D	1000 psi air	digital	psi/bar/Nm/lbf.ft	427.17	97.64	48.82	1.85	80°	66.1	18.68	11.27	19.74

Optional coupler sets for simultaneous operation of multiple torque wrenches (one set supplied fitted as standard)

Model number	Description
TP-CS1	Single set of male/female flat face couplers, for simultaneous operation of two hydraulic wrenches
TP-CS2	Double set of male/female flat face couplers, for simultaneous operation of three hydraulic wrenches
TP-CS3	Triple set of male/female flat face couplers, for simultaneous operation of four hydraulic wrenches